

The wheel chair accessible “Dolphin” bubbler by Parkequip has been designed to meet the needs of all people including those with varying degrees of disabilities.

There are no bowls or drains to clog, so maintenance costs normally associated with bubblers have now been eliminated by our unique approach to handling water.

- Sleek Design
- Wheel Chair Accessible
- Low Maintenance
- No drains or bowls to clean
- Graffiti Resistant
- Available in a range of stone finishes
 - White Marble
 - Sandstone
 - Pink Granite
 - Marble
 - Millstone

OPTIONAL CONTROL FOUNTAINS

- Single Combination Press Button Fountain Head
- Side Mounted Remote Button
- Electronic Auto Sense Control Switch

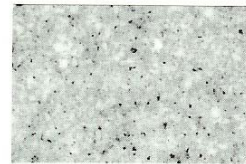

White Marble 865

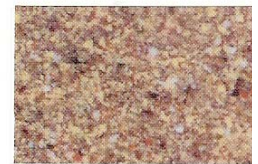

Sandstone 927

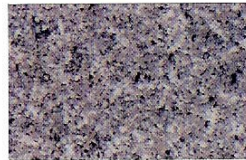

Pink Granite 866



Marble 251

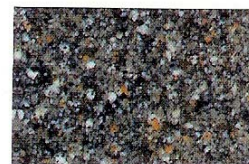

Millstone 867

REGISTERED DESIGN

“ Another Quality Australian Made product from Parkequip ”

Technical Specifications

DOLPHIN BUBBLER

MODEL MAB 001

MATERIAL

High Density Polyethylene Plastic
compoll LL6488, UV stabilised plastic

ULTRAVIOLET STABILITY

Cotene compounded polyethylene colours contain an excellent UV additive package of UV-8, which is designed to handle the harsh UV conditions in Australia

FINISH EFFECTS

White Marble
Sandstone
Pink Granite
Marble
Millstone

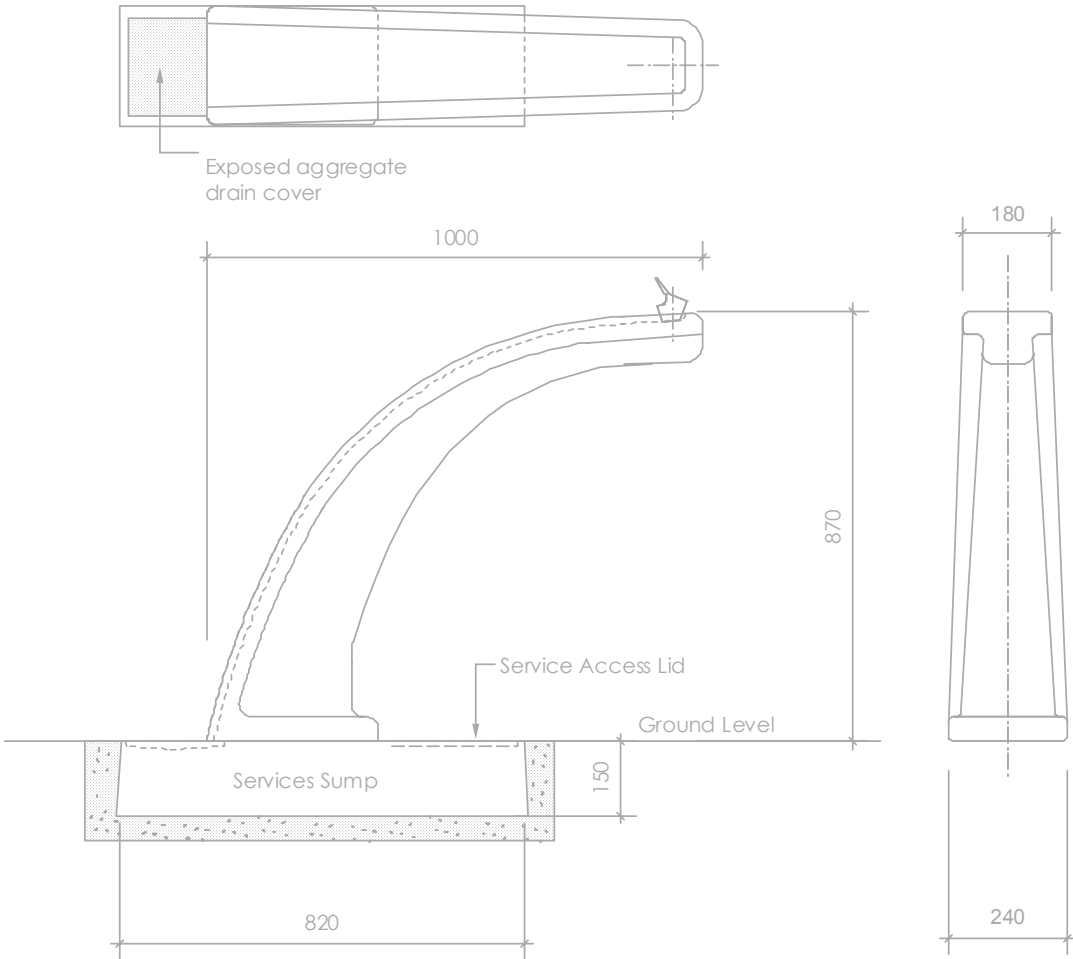

Copyright: All designs remain the intellectual property of Parkequip Pty Ltd

PARKEQUIP PTY LTD

12 / 77 Newton Rd Wetherill Park NSW 2164
Ph 02 9725 5604 Fax 02 9725 4420

ABN 86 088 184 927
www.parkequip.co.au
Email: info@parkequip.com.au